

RotorChamp

ROTARY SCREW AIR COMPRESSORS, 20-50 HP

► Convenient



► Efficient



► Available



► Flexible



CHAMPION[®]

Big things come in small packages.

At Champion, air compressors are the only product we think about. We know and understand the application of this product in different markets. Our goal is to provide you with a product that fulfills—and exceeds—your expectations and requirements.

In today's market, the reliability of an air compressor has a direct relationship to your bottom line. You also want a compressor that is user-friendly and can be installed right where it is needed.

The RotorChamp™ 20–50 horsepower compressors give you all these things and more. Drawing from our experience in the automotive and industrial markets, our ultra-efficient compressor package has the design and compact footprint that enable it to be installed right where you want it, giving you the advantage of flexibility.

The integrated air end technology uses a belt-driven design, giving you added flexibility for changing discharge pressures, when necessary.

We maximize return on your investment, by providing a fully-equipped, super quiet compressor package at one low price.

A state-of-the-art rotary screw compressor.

Not all screw compressors are created equal. The RotorChamp 20–50 horsepower units set a new standard in air compressor packages.

- ▶ Increased flow
- ▶ Low noise levels
- ▶ 30% fewer parts compared to conventional units

- ▶ Leak-free design
- ▶ Oil carryover less than 2 PPM
- ▶ Quick and easy service

For you, these benefits represent considerable savings in energy consumption and maintenance time. Champion has recognized the need for the RotorChamp to provide an efficient and environmentally-friendly compressor that will not only provide reliable service but save you operational cost for years to come.

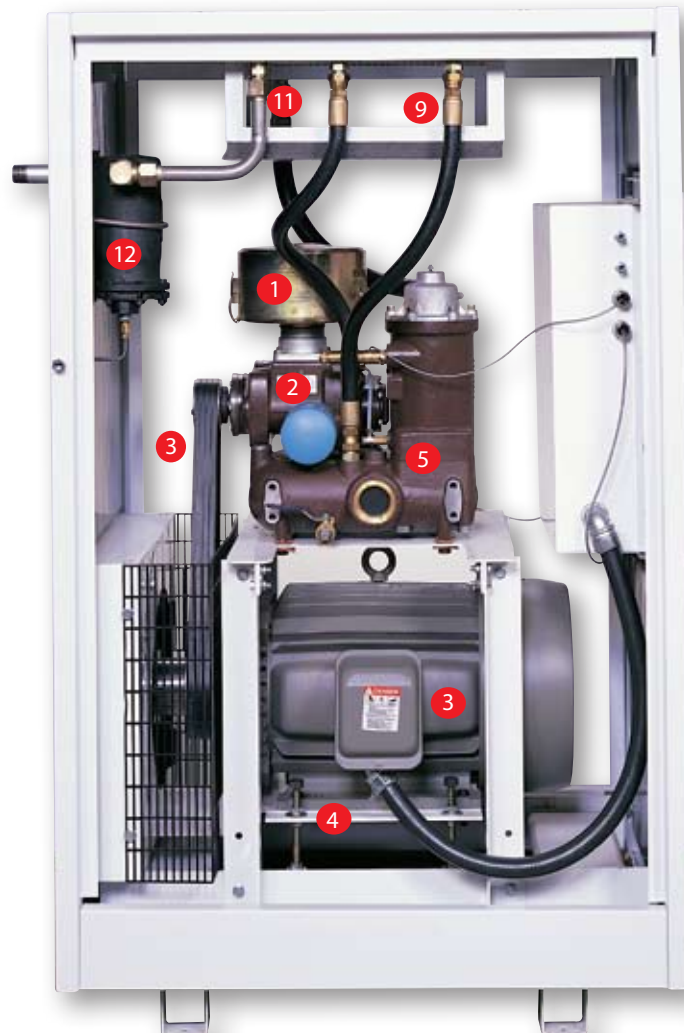

Rotary Screw Compressor Principle

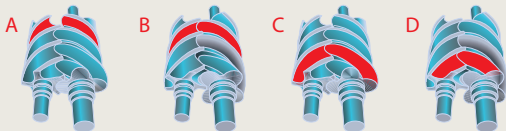

- A – Air Inlet
- B, C – Air Compression
- D – Compressed Air Discharge

State of the Art

1. Air is drawn through an inlet air filter
2. into the air end, and oil is injected between the rotors.
3. The air end is rotated with belts driven by an electric motor. **Motors come with a standard 5 year warranty!**
4. The adjustment of belt tension through a motor mounting plate is quick and easy.
5. From the air end, the air-oil mixture flows into the unit, where three-stage separation takes place. The first stage is carried out by a baffle in the oil sump directly after the air end.
6. The second is the intelligent cyclone stage
7. and the final is carried out by the separation elements.
8. Separated oil remains on the bottom of the module unit, where the thermostat valve
9. passes it through the oil-cooler
10. into the oil filter, or directly to the oil filter, depending on the temperature. The oil then returns to the air end.
11. Clean compressed air flows into the after cooler, where water is separated through condensation.
12. The condensate is automatically removed in the water separator.

RotorChamp compressors are fully automatic and deliver air on demand. When air consumption ceases, the compressor switches to no-load. If there is no demand for compressed air, the compressor stops automatically until air is needed again. This maximizes compressor efficiency and reduces operating costs.

Champion's exclusive integrated air end design delivers both small footprint and serviceability in one!

A new generation of air end design.

The heart of the Champion compressor package is a state-of-the-art air end concept that incorporates a screw compressor air end with an assembly base and several other key components that have not traditionally been a part of the air end. The integrated design eliminates the need for additional interconnecting piping. This reliable, field-proven design saves space, offers "leak-proof" operation due to fewer connections and keeps air clean and dry with a three-stage air/oil separation system. Down the road, you'll experience less downtime and lower component replacement costs.

A smarter package configuration.

The RotorChamp utilizes an integrated air end solution in an "over-and-under" package configuration. This design offers ultra-compact, small-footprint compressor package solutions. The RotorChamp packages require 30% fewer parts than the conventional compressor package designs. The result is less maintenance, less downtime and reduced inventory and parts replacement costs.

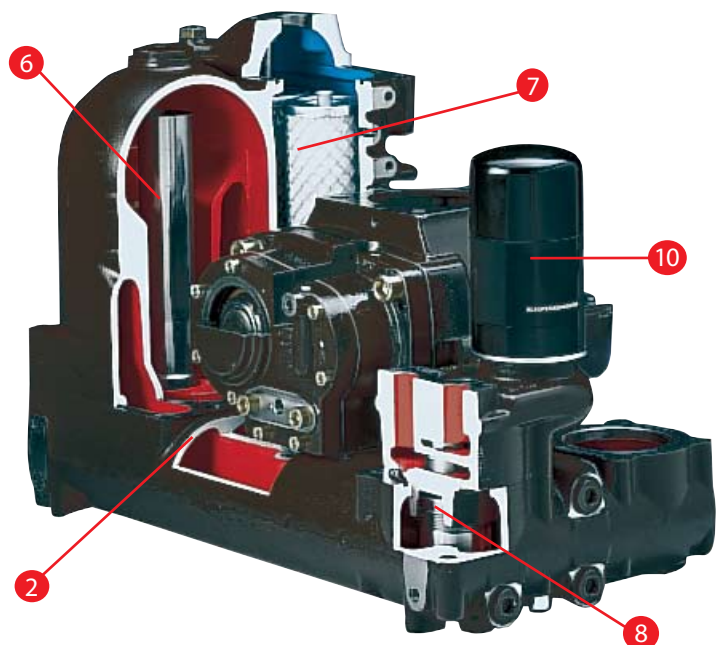

Loaded with options—as the standard.



RCS20-RCS30
Model EFC

Maximum Convenience.

The RotorChamp package design represents a new approach in compressor design. The air ends of these compressor packages are designed to minimize oil leaks, keeping lubricant where it should be—inside your compressor, not on your shop floor. Unlike most reciprocating air compressors, the RotorChamp provides cool, clean compressed air. The built-in, three-stage oil separation system minimizes oil carryover in the compressed air, making it a very user-friendly and easy-to-operate compressor package.

Maximum running time.

The RotorChamp is designed to provide continuous 24-hour operation. Proven components provide a long and trouble-free operating life and ensure high reliability, even in the toughest working environments. The air end design evolved from train braking applications where dirt, dust and temperature ranges are extreme and where absolute reliability is crucial.

Integrated Design Is Best

Three-Stage Air/Oil Separation

- ▶ Mechanical Redirection
- ▶ Cyclone, Centrifugal-Type Air Direction
- ▶ Pleated Filter, Inside-Out Final Separation
- ▶ Less than 2 PPM Carryover Measured before the Aftercooler

Maintenance-Free, Leak-Proof Operation

O-Ring Seals and Fewer Connection Points

Modular Air End Design

Readily Accessible Bolt-On Configuration (Unlike Encapsulated Designs Which Require Total Replacement)

Compact, Integrated Design

Allows for the Smallest Footprint in the Industry

Energy-Saving Efficient Rotor Profile

Lower Annual Operating Costs

The integrated air compressor system

is the marriage of a proven air end design and cutting-edge package technology. A Champion exclusive, this design integration of a time-tested air end with a three-stage oil separation system results in 30% fewer connection points.

Reliable, Consistent Operation Via New Generation Bearings

Capable of Three Times More Load than Conventional Designs

Time-Tested Air End

Tens of Thousands of Air Ends Running Throughout the World

Integrated, 3-Way Thermal Mixing Valve

Minimizes Leak Points Via Integrated Design

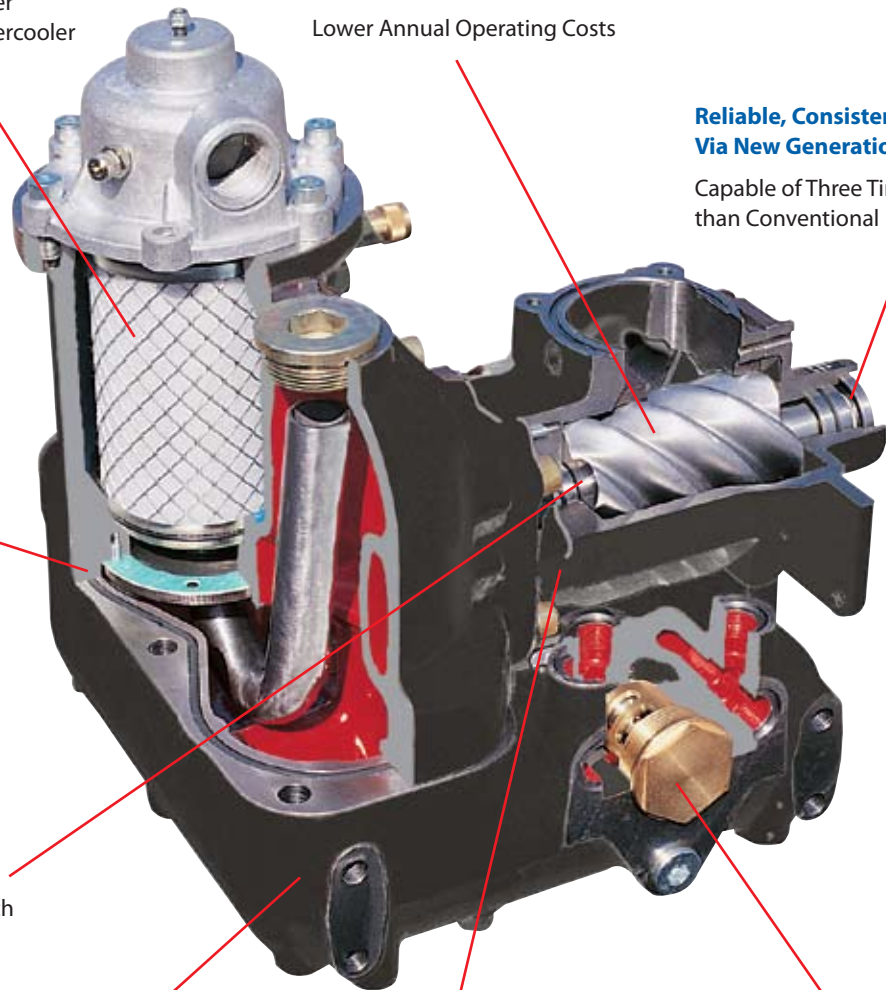

Microprocessor simplicity and power

Never Out of Control.

RotorChamp compressors use microprocessor control technology because it's the simplest, yet most powerful compressor control design available. These controllers are built on the foundation of being easy to operate and read, so you just push a button and get back to work. Then if service is necessary or a problem exists with the compressor, the controller communicates the need. With the AirSmart™ controller, you don't waste time troubleshooting or tracking service requirements. RotorChamp controllers are designed to take control!



AirSmart™

RotorChamp Specifications

	STYLE MODEL HORSEPOWER	RCS20 EFC 20	RCS25 EFC 25	RCS30 EFC 30	RCS40 EFD 40	RCS50 EFD 50
MOTOR DATA	Pressure-PSIG					
Nameplate HP	All	20	25	30	40	50
Service Factor	All	1.15	1.15	1.15	1.15	1.15
Speed RPM	All	3600	3600	3600	3600	3600
CAPACITY PKG						
ICFM	100	83	106	127	182	225
	125	75	96	116	155	197
	150	66	86	103	137	174
	175	57	74	95	128	159
COMPRESSOR POWER						
PKG BHP	100	21.4	27.0	32.8	43.7	54.8
	125	22.0	27.6	33.0	43.1	54.1
	150	22.0	27.4	32.6	43.9	54.8
	175	21.5	26.5	32.9	44.8	54.4
COOLING FAN POWER	All	On Motor	On Motor	On Motor	On Motor	On Motor
PACKAGE DIMENSIONS:						
Base-mounted w/enclosure (In.)	Length	48	48	48	55	55
	Width	30	30	30	32	32
	Height	66	66	66	69	69
PACKAGE WEIGHT:						
Base-mounted w/enclosure (lbs.)	All	1130	1210	1280	1419	1474

Note: All data shown is approximate

Specifications

RotorChamp 20–50 HP Standard Equipment

- ▶ Heavy Duty Inlet Air Filter with Replaceable Element
- ▶ Easy Access Air/Oil Separator Element
- ▶ Heavy Duty Radiator Air/Oil Aftercooler
- ▶ Easy to Read Oil Level Sight Gauge
- ▶ Single Stage, Rotary Screw, Integrated Air Compressor Bare
- ▶ Open Drip-Proof Drive Motor:
460 Volt, 3 Phase, 60 HZ, 1.15 S.F., 3600 RPM (20–50 HP)
- ▶ Moisture Separator and Trap
- ▶ Thermostatic Mixing Valve for Temperature Control
- ▶ Small, Compact Package Footprint
- ▶ Adjustable Hingeplate for Easy Belt Tensioning
- ▶ Rigid Steel Base on Isolators for Smoother Operation
- ▶ Quiet Enclosure: 75 dBA (20–50 HP)
- ▶ OSHA Approved Steel Drive Guard
- ▶ Pressure Relief Valve
- ▶ Factory Fill with RotorLube 4000 Rotary Screw Lubricant
- ▶ NEMA 4 Control Enclosure
 - Mounted and Wired Full-Voltage Magnetic Motor Starter
 - Control Voltage Transformer
 - Emergency Stop Button

Optional Equipment

- ▶ Alternate Voltages — 200, 230 and 575
- ▶ TEFC and ODP High Efficiency Drive Motors
- ▶ Factory Fill RotorLube 4000 Food Grade Rotary Screw Lubricant
- ▶ Factory Fill RotorLube 8000 Rotary Screw Lubricant
- ▶ Communications/Sequencing module
- ▶ Wye Delta Start (20–50 HP)

AirSmart™ Microprocessor Controller

- ▶ Low voltage 24 VDC operation
- ▶ Two pressure transducer inputs
- ▶ Informative control panel
 - 4 line by 20 character LCD display
 - 4 status LEDs for “at a glance” compressor status
 - 9 buttons for easy control and menu navigation
 - Multiple language support
- ▶ The controller is feature rich with maintenance and error handling information including:
 - **29** different sources for **advisories**
 - **68** different sources for **system shutdown**
 - Advisory/shutdown history stored in non-volatile memory
 - > Last 6 advisories
 - > Last 6 shutdowns
 - Distributor contact information
- ▶ Part number is displayed when consumable item causes advisory or shutdown
- ▶ Sequence capability for control of up to eight AirSmart controlled compressors*
- ▶ RS-232 serial communications for local monitoring*
- ▶ Ethernet communications for remote monitoring*

* With optional communications/sequencer module.

Always expect more from Champion.

Your Champion distributor has the tools and expertise to serve you in every way. Whether you are looking for parts, service or advice, your Champion distributor will help you realize the most return on your RotorChamp investment.

The RotorChamp air end is covered by a full two-year warranty. The Champion worldwide parts distribution network means any part will be delivered, whenever and wherever it is needed.

With the new, smart package configuration, you get the standard features you need, along with the flexibility to meet the requirements of your particular application, all supported by a worldwide parts distribution network.

The Irreplaceable Compressor System with the Replaceable Air End

- ▶ Time-proven air end is fully detachable for easy maintenance.
- ▶ Integrated, space-saving design allows full access to all service areas.
- ▶ Reduced piping and fittings provide virtually leak-proof operation.

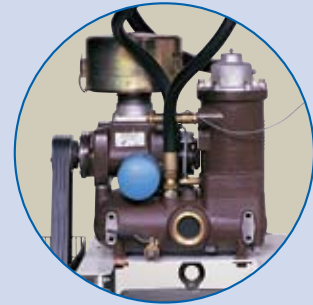

CHAMPION[®]

1301 North Euclid Avenue
Princeton, Illinois 61356 USA
Phone 888/436-5499
Fax 815/872-0421
E-mail: Champion@championpneumatic.com
www.championpneumatic.com

© 2009 Gardner Denver, Inc.
Printed in U.S.A.
CS-RC-20-50 1st Ed. 3/09
Supersedes C13-8-218 5th Ed. 4/06

Due to Champion's continuing product development program, specifications and materials are subject to change without notice or obligation.

Member

